



EZflow Drainage System for the Crawl Space

PLACEMENT

For **EZflow** drainage crawl space dewatering systems, it is recommended that a 10 to 12 inch wide trench be excavated along the interior foundation wall a minimum of 9 inches deep below the floor surface elevation for a soil floor or 9 inches below the bottom of floor slab elevation for a concrete floor. The trench must slope towards and discharge into an excavated sump. Installation should be avoided during flooded conditions or when no other outlet exists.

PRODUCT

7-inch EZflow drainage bundles with 3-inch pipe are installed along the bottom of the trench with appropriate fittings at trench bends. A minimum 2-inch layer of permeable backfill is placed above the bundle to support poured concrete in slab repair situations or brought to finished grade where the concrete slab exists.

TOOLS NEEDED TO COMPLETE INSTALLATION

- Hilti TE 2 Hammer Drill or equivalent with 1/4" Hammer Drill Bit
- Hilti TE 3000 Jack Hammer or equivalent with Chisel Bit - Tall crawl spaces 5 ft. or higher
- Hilti TE 60 Hammer Drill or equivalent with Chisel Bit - Crawl spaces 5 ft. or lower
- 5 gal Buckets
- Shovel
- Rake
- Trash Bags for Insulation Removed

DIAGRAM 1:

Crawl space with
concrete slab present

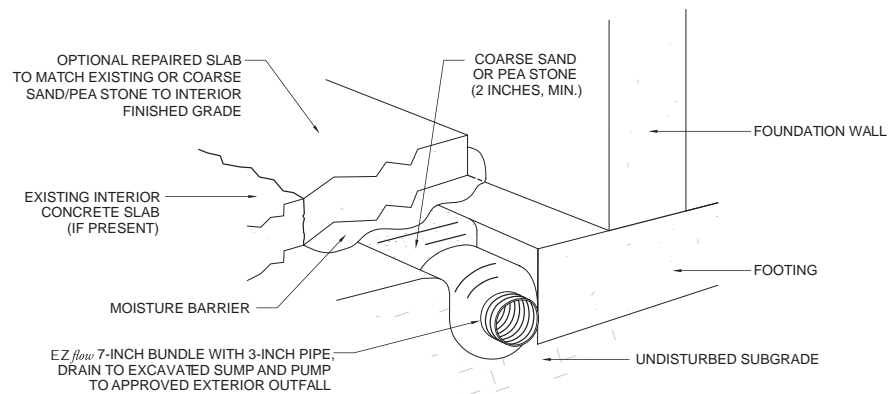

DIAGRAM 2:

Crawl space without
concrete slab present





EZflow Drainage System for the Crawl Space

INSTALLATION STEPS

The steps below offer typical installation practices for crawlspace dewatering drains, and will vary based on site conditions.

1. Excavate a trench along the inside perimeter of the foundation wall being careful to not damage or interfere with existing utilities. The trench should be a minimum of 9 inches deep and should be sloped evenly towards an excavated sump or discharge point.

NOTE: In the event that a concrete slab is present, use a jack hammer or concrete chipper to remove the concrete as needed to install the EZflow drainage.

NOTE: If the foundation is constructed with concrete block, use a hammer drill to drill 1/4" weep holes into each hollow of the concrete blocks. Be sure to drill a hole where each of the blocks meet as well. This will help to prevent the hollows from filling with and holding water.

2. Connect the 7-inch EZflow bundle with 3-inch pipe to the excavated sump outfall and connect additional bundles to run the entire length of the trench. Use an end cap at any system high point and fully insert the proper couplings at all system connections.
3. Place a minimum 2-inch layer of clean, coarse sand or washed pea gravel above the bundle to support poured concrete in slab repair situations, or place the sand/gravel to finished grade where no concrete slab exists.
4. For floors with a concrete slab finish, restore concrete slab that was removed.