

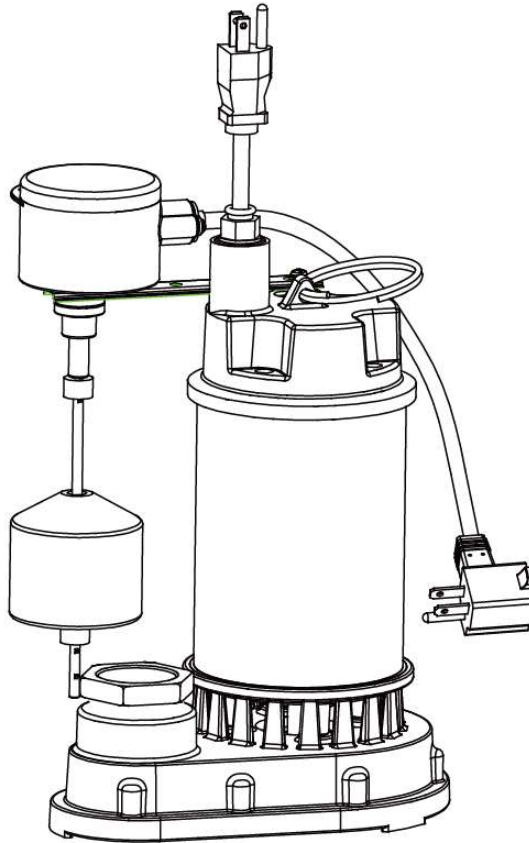

Westinghouse

OWNER'S MANUAL

SUBMERSIBLE SUMP PUMP



Model# WH50SS / WH75SS

PERFORMANCE

Model	HP	GPH of Water @ Total Feet of Lift						Max. Lift
		0 ft.	5 ft.	10 ft.	15 ft.	20 ft.	25 ft.	
WH50SS	1/2	5200	4650	4200	3650	3000	2200	30 ft.
WH75SS	3/4	6000	5500	5100	4650	4100	3400	30 ft.

SAFETY INSTRUCTIONS

1. Do not pump flammable or explosive liquids such as oil, gasoline, kerosene, ethanol, etc. Do not use in the presence of flammable or explosive vapors. Using this pump with or near flammable liquids can cause an explosion or fire, resulting in property damage, serious personal injury, and/or death.
2. ALWAYS disconnect the power to the pump before servicing.
3. Do not touch the motor housing during operation. The motor is designed to operate at high temperatures. Do not disassemble the motor housing.
4. Do not handle the pump or pump motor with wet hands or when standing on a wet or damp surface, or in water before disconnect the power.
5. Release all pressure and drain all water from the system before servicing any component.
6. Secure the discharge line before starting the pump. An unsecured discharge line will whip, possibly causing personal injury, and/or property damage.
7. Extension cords may not deliver sufficient voltage to the pump motor. Extension cords present a life threatening safety hazard if the insulation becomes damaged or the connection ends fall into water. The use of an extension cord to power this pump is not permitted.
8. Wear safety goggles at all times when working with pumps.
9. This unit is designed only for use on 115 volts (single phase), 60 Hz, and is equipped with an approved 3-conductor cord and 3-prong grounded plug. Do not remove the ground pin under any circumstances. The 3-prong plug must be directly inserted into a properly installed and grounded 3-prong, grounding-type receptacle. Do not use this pump with a 2-prong wall outlet. Replace the 2-prong outlet with a properly grounded 3-prong receptacle (a GFCI outlet) installed in accordance with the National Electrical Code and local codes and ordinances. All wiring should be performed by a qualified electrician.
10. Protect the electrical cord from sharp objects, hot surfaces, oil, and chemicals. Avoid kinking the cord. Do not use damaged or worn cords.
11. Failure to comply with the instruction and designed operation of this unit may void the warranty. ATTEMPTING TO USE ADAMAGED PUMP can result in property damage, serious personal injury, and/or death.
12. Ensure that the electrical circuit to the pump is protected by a 15 Amp fuse or circuit breaker.
13. Do not lift the pump by the power cord.
14. Know the pump and its applications, limitations, and potential hazards.
15. Secure the pump to a solid base. This will aid in keeping the pump in a vertical orientation. This is critical in keeping the pump operating at maximum efficiency. It will also help prevent the pump from clogging resulting in premature failure.
16. Periodically inspect the pump and system components to ensure the pump suction screen is free of mud, sand, and debris. Disconnect the pump from the power supply before inspecting.
17. Follow all local electrical and safety codes, along with the National Electrical Code (NEC). In addition, all Occupational Safety and Health Administration (OSHA) guidelines must be followed.
18. The motor of this pump has a thermal protector that will trip if the motor becomes too hot. The protector will reset itself once the motor cools down and an acceptable temperature has been reached. The pump may start unexpectedly if it is plugged in.
19. Ensure the electrical power source is adequate for the requirements of the pump.

20. This pump is made of high-strength, corrosion-resistant materials. It will provide trouble-free service for a long time when properly installed, maintained, and used. However, inadequate electrical power to the pump, dirt, or debris may cause the pump to fail. Please carefully read the manual and follow the instructions regarding common pump problems and remedies.

PRE-INSTALLATION

APPLICATION

- This submersible sump pump is designed for home sump applications. Use this pump only for pumping water.
- This unit is not designed as a waterfall or fountain pump, or for applications involving salt water or brine! Use with waterfalls, fountains, salt water or brine will void warranty.
- Do not use where water recirculates.
- Not designed for use as a swimming pool drainer.

TOOLS REQUIRED

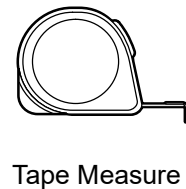
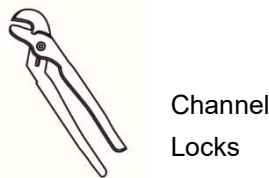
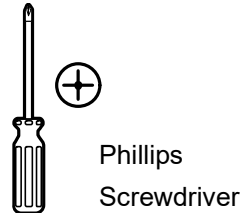
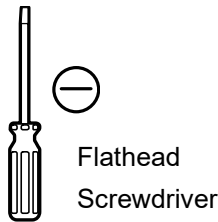

MATERIALS REQUIRED (NOT INCLUDED)

NOTE: Parts shown below not to scale.

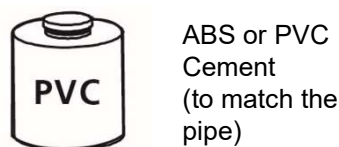
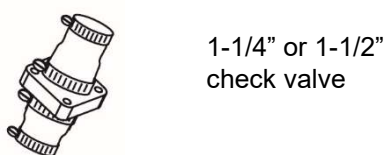
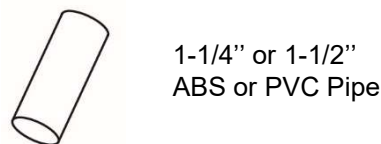
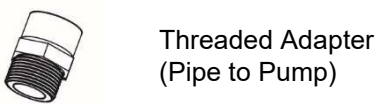

SPECIFICATIONS

Power supply	115V, 60 HZ., 15 Amp Circuit
Liquid temp. range	32°F to 95°F (0°- 35°C)
Discharge size	1-1/2 in. FNPT or 1-1/4 in. FNPT (with adaptor)
Sump basin	Min. 14 in. (356 mm) diameter, 18 in. (457 mm) depth for tethered switch Min. 10 in. (254 mm) diameter, 14 in. (356 mm) depth for vertical switch

NOTE: Do not reduce size of discharge pipe or hose below 1-1/4 in. diameter. If discharge is too small, pump will overheat and fail prematurely. This pump is designed for use in a residential sump only. Only pump water with this pump.

INSTALLATION

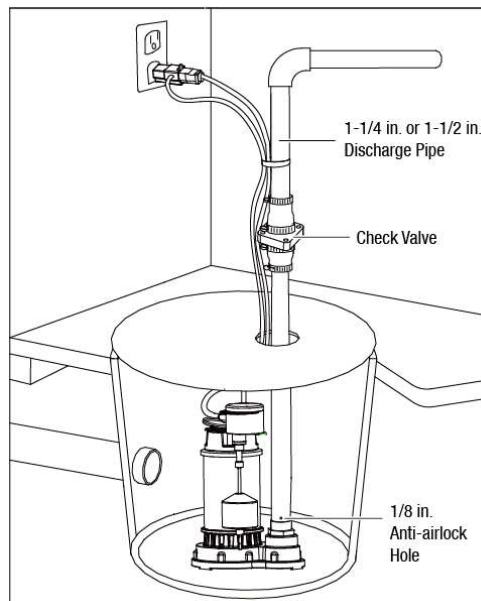

Install the pump in sump pit with minimum diameter of 10 in. (254 mm) for models equipped with vertical switches and 14 in. (356 mm) for tethered float switch models. The sump depth should be 14 in. (356 mm) for vertically switched models and 18 in. (457 mm) for tethered models. Construct the sump pit of tile, concrete, steel or plastic. Check local codes for approved materials and for proper installation.

1. Install the pump in a pit so that the switch operating mechanism has maximum possible clearance.
2. The pump should not be installed on clay, earth or sand surfaces. Clean the sump pit of small stones and gravel which could clog the pump. Keep the pump inlet screen clear.

NOTE: Do not use ordinary pipe joint compound on plastic pipe. Pipe joint compound can attack plastics.

3. Install discharge plumbing. Use rigid plastic pipe and wrap threads with PTFE pipe thread sealant tape. Screw pipe into the pump hand tight plus 1-1/2 turns.

CAUTION: Risk of flooding. Can cause personal injury and/or property damage. If a flexible discharge hose is used, make sure the pump is secured in the sump to prevent movement. Failure to secure the pump may allow pump movement, switch interference and prevent the pump from starting or stopping.

4. To reduce motor noise and vibrations, a short length of rubber hose (1-7/8 in. (47.6 mm) I.D., e.g. radiator hose) can be connected into the discharge line near the pump using suitable clamps.
5. Install an in-line check valve or an in-pump check valve to prevent flow backwards through the pump when the pump shuts off.

NOTE: If your check valve is not equipped with an air bleed hole to prevent air locking the pump, drill a 1/8 in. (3.2 mm) hole in the discharge pipe just above where the discharge pipe screws into the pump discharge. Be sure the hole is below the waterline and the check valve to prevent air locks.

- Power Supply: Pump is designed for 115 V, 60 Hz, operation and requires a minimum 15 amp individual branch circuit.

Plug the pump power cord plug into the piggyback switch plug outlet, and then plug the switch plug into a 115V GFCI power outlet for automatic operation. The pump will start operating if the float switch moves over the pump top. The water will be pumped out. When the water lowers to certain level, the float switch will turn off the pump. Or plug the pump power cord plug into a 115V GFCI power outlet directly for manual operation. Pump will start operating immediately once it plug to the GFCI and drain water out, when the water moved out, you must unplug the pump immediately.

The following picture shows a typical connection for pumps with the piggy-back plug, for manual and automatic operations.

Automatic - Plug float cord into GFCI outlet, then plug pump cord into float cord.

Manual - Plug pump cord directly into GFI outlet.

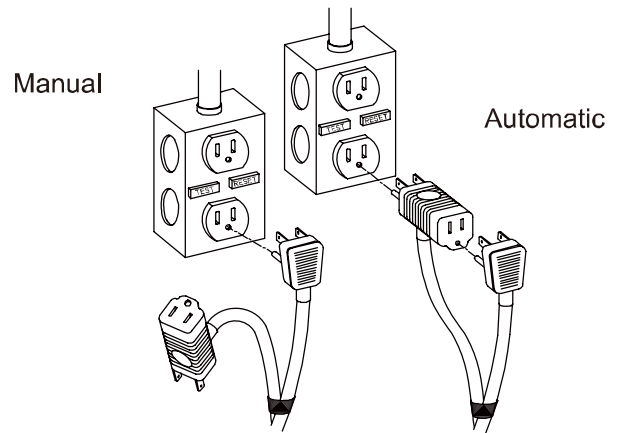

WARNING: Risk of electric shock. Can shock, burn or kill. Pump should always be electrically grounded to a suitable electrical ground such as a grounded water pipe or a properly grounded metallic raceway, or ground wire system. Do not cut off the round ground pin.

- If the pump discharge line is exposed to outside subfreezing atmosphere, a portion of line exposed must be installed so any water remaining in the pipe will drain to the outfall by gravity. Failure to do this can cause water trapped in the discharge to freeze which could result in damage to the pump.
- After the piping and check valve have been installed, the unit is ready for operation.
- Check the pump operation by filling the sump with water and observing pump operation through one complete cycle.

CAUTION: Risk of flooding. Can cause personal injury and/or property damage. Failure to make this operational check may lead to improper operation, premature failure, and flooding.

OPERATION

WARNING: Risk of electric shock. Can shock, burn or kill. Do not handle a pump or pump motor with wet hands or when standing on a wet or damp surface, or in water.

- The shaft seal depends on water for lubrication. Do not operate the pump unless it is submerged in water as the seal may be damaged if allowed to run dry.
- The motor is equipped with an automatic reset thermal protector. If temperature in the motor should rise unduly, the switch will cut off all power before damage can be done to the motor. When the motor has cooled sufficiently, the switch will reset automatically and restart the motor. If the protector trips repeatedly, the pump should be removed and checked. Low voltage, long extension cords, clogged impeller, very low head or lift, or a plugged or frozen discharge pipe, etc., could cause the protector to trip.
- The pump will not remove all water. If operating a pump manually, and suddenly no water comes out of the discharge hose, shut off the unit immediately. The water level is probably very low and the unit has broken prime.

WARNING: Risk of electric shock. Can shock, burn or kill. Before attempting to check why the unit has stopped operating, disconnect power from the unit.

CAUTION: Do Not Change the preset tether length.

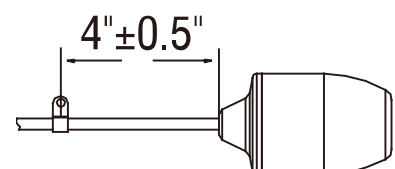

CARE AND CLEANING

CAUTION: Always use the handle to lift the pump. Never use the power cord to lift the pump. To avoid skin burns, unplug the pump and allow time for it to cool after periods of extended use.

Do

- When the power is disconnected, inspect the pump suction screen and remove all debris, then plug the pump back into the grounded (GFCI) outlet.

Do Not

- Do not disassemble the motor housing. This motor has NO repairable internal parts, and disassembly may cause leakage or dangerous electrical wiring issues.
- Do not lift up the pump by the power cord.

To clean a pump clogged with debris:

- Unplug the pump from electrical power.
- Unscrew the stainless screws, and remove the volute/bottom seal plate.
- Use a flathead screwdriver to hold the shaft, then turn the impeller counterclockwise to release the impeller.
- Remove debris from around the shaft and on/under the impeller.
- Reassemble the pump.

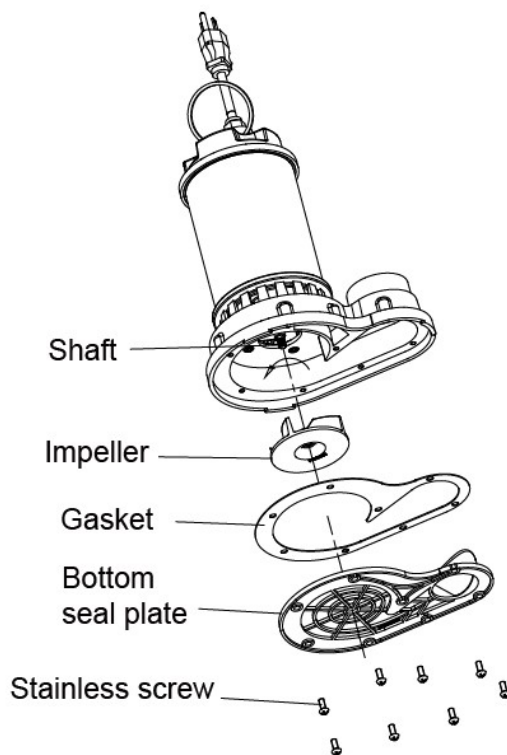

TROUBLESHOOTING

Problem	Possible Cause	Corrective Action
The pump does not start or run.	<ol style="list-style-type: none"> 1. The fuse is blown. 2. The breaker is tripped. 3. The plug is disconnected. 4. The plug is corroded. 5. There is thermal overload. 6. The switch failed. 7. The motor failed. 	<ol style="list-style-type: none"> 1. Replace the fuse. 2. Reset the breaker. 3. Secure the plug. 4. Clean the plug prongs. 5. Unplug for 30 minutes and then plug in again. 6. Replace the switch. 7. Replace the pump.
The pump operates but pumps little or no water.	<ol style="list-style-type: none"> 1. The screen is blocked. 2. Debris is caught in the impeller or discharge. 3. The impeller is loose on the shaft or the impeller is broken. 	<ol style="list-style-type: none"> 1. Clean the screen. 2. Remove the debris. 3. Reassemble the impeller or replace the impeller.
The pump starts and stops too often.	<ol style="list-style-type: none"> 1. There is a backflow of water from the piping or the check valve is leaking. 2. The float switch is stuck. 	<ol style="list-style-type: none"> 1. Install a check valve or replace the check valve. 2. Clean the float switch to make sure the float moves up and down freely.
The pump will not shut off.	<ol style="list-style-type: none"> 1. The switch is tangled. 2. The float switch is faulty. 3. The float is obstructed. 	<ol style="list-style-type: none"> 1. Reposition the pump and make sure the switch moves freely. 2. Replace the switch. 3. Remove the obstruction.

WARRANTY

WESTINGHOUSE RESIDENTIAL PUMPS

LIMITED PUMP WARRANTY

LIMITED WARRANTY

Westinghouse Residential Pumps warrants the products covered by this Limited Warranty to be free from defects in material or workmanship for the periods set forth below.

- 1/2 HP SS SUBMERSIBLE SUMP PUMP (WH50SS 860010653623) – 3 years from date of purchase
- 3/4 HP SS SUBMERSIBLE SUMP PUMP (WH75SS 860010653616) – 3 years from date of purchase

Subject in all respects to the terms and conditions set forth in this Limited Warranty, during the applicable warranty period, Westinghouse Residential Pumps will repair or replace to the original consumer any portion of the subject product which proves defective due to defective materials or workmanship.

The determination of whether to repair or replace defective product or components shall be in the sole and absolute discretion of Westinghouse Residential Pumps. Westinghouse Residential Pumps may elect to inspect any product claimed to be defective under this limited warranty to confirm applicability of this limited warranty.

THIS WARRANTY SETS FORTH WESTINGHOUSE RESIDENTIAL PUMPS SOLE OBLIGATION AND CONSUMER'S EXCLUSIVE REMEDY FOR DEFECTIVE PRODUCT.

GENERAL TERMS AND CONDITIONS; WARRANTY EXCLUSIONS

This Limited Warranty shall not apply to damage due to acts of God, normal wear and tear, normal maintenance services and the parts used in connection with such service, damages caused by lightning strikes or other acts of nature, power surges or conditions beyond the control of Westinghouse Residential Pumps. This Limited Warranty shall not apply to products which, in the sole judgment of Westinghouse Residential Pumps, have been subject to negligence, abuse, accident, misuse, tampering, alteration, improper installation, operation, maintenance or storage.

This Limited Warranty will be VOIDED if any of the following conditions are found to have occurred:

- Commercial or industrial use of the product.
- The product is not installed in accordance with applicable codes, ordinances, and good trade practices.
- The product is not operated or maintained in accordance with the printed instructions provided.
- The product is used for purposes other than those for which it was designed and manufactured.
- The product is connected to voltage other than indicated on nameplate or labels.
- The product is exposed to abrasive or corrosive substances including but not limited sand, gravel, cement, grease, plaster, mud, tar, oil, gasoline, solvents.
- The product has been used for pumping liquids below 32°F or above 95°F.
- The product has been allowed to operate dry (liquid supply cut off).

Westinghouse Residential Pumps shall NOT be responsible or liable for the cost of field labor or other charges incurred by customer in removing or reinstalling any product, part, or component.

THIS LIMITED WARRANTY DOES NOT COVER REPLACEMENT PARTS FOR FAILURE DUE TO NORMAL WEAR AND TEAR. THIS LIMITED WARRANTY DOES NOT COVER THE COST OR VALUE OF DAMAGED PROPERTY, INCLUDING ANY PROPERTY AFFECTED BY WATER OVERFLOW, SEEPAGE OR FLOODING.

LIMITATIONS

Westinghouse Residential Pumps only obligation, and user's only remedy, shall be the replacement and/or repair by Westinghouse Residential Pumps of the product as described above. WESTINGHOUSE RESIDENTIAL PUMPS SHALL NOT BE LIABLE FOR ANY INJURY, LOSS OR DAMAGE, DIRECT, INCIDENTAL OR CONSEQUENTIAL (INCLUDING, BUT NOT LIMITED TO, INCIDENTAL OR CONSEQUENTIAL DAMAGES FOR LOST PROFITS, INJURY TO PERSON OR DAMAGE TO PROPERTY, OR ANY OTHER INCIDENTAL OR CONSEQUENTIAL LOSS), ARISING OUT OF THE USE OR THE INABILITY TO USE THE PRODUCT, AND THE USER AGREES THAT NO OTHER REMEDY SHALL BE AVAILABLE TO IT. Before using, the user shall determine the suitability of the product for user's intended use, and user assumes all risk and liability in connection therewith.

TO THE MAXIMUM EXTENT PERMITTED BY LAW, THE WARRANTY AND REMEDY DESCRIBED IN THIS LIMITED WARRANTY IS AN EXCLUSIVE WARRANTY AND REMEDY AND IS IN LIEU OF ALL OTHER WARRANTIES OR REMEDIES, ORAL, WRITTEN, STATUTORY, EXPRESSED OR IMPLIED, WHICH OTHER WARRANTIES AND REMEDIES ARE HEREBY EXPRESSLY EXCLUDED, INCLUDING BUT NOT LIMITED TO ANY IMPLIED WARRANTY OF MERCHANTABILITY OR FITNESS FOR A PARTICULAR PURPOSE, TO THE EXTENT EITHER APPLIES TO A PRODUCT SHALL BE LIMITED IN DURATION TO THE PERIODS OF THE EXPRESSED WARRANTIES GIVEN ABOVE. Any oral statements about the product made by Westinghouse Residential Pumps, its representatives, or any other parties do not constitute warranties and shall not be relied upon by the user.

NO AGREEMENT VARYING OR EXTENDING THE FOREGOING WARRANTY AND RELATED REMEDIES WILL BE BINDING UPON WESTINGHOUSE RESIDENTIAL PUMPS UNLESS IN WRITING, SIGNED BY A DULY AUTHORIZED OFFICER OF WESTINGHOUSE RESIDENTIAL PUMPS.

WESTINGHOUSE RESIDENTIAL PUMPS LIABILITIES IN CONNECTION WITH THE ORDER TO WHICH THIS LIMITED WARRANTY RELATES, WHETHER IN CONTRACT, IN TORT, UNDER ANY WARRANTY OR OTHERWISE, SHALL NOT EXCEED THE TOTAL PURCHASE PRICE OF THE PRODUCT.

Some jurisdictions do not allow limitations on how long an implied warranty may last and so the above limitation may not apply to you. The above limitation or exclusion of incidental or consequential damages may not apply to you if you are in a state that does not allow the limitation or exclusion of incidental or consequential damages.

If any term in this Limited Warranty is held to be illegal or unenforceable, the legality or enforceability of the remaining terms shall not be affected or impaired.

WARRANTY CLAIM SUBMISSIONS

All claim submissions under this Limited Warranty should be marked "WARRANTY CLAIM SUBMISSION" and must include a description of the defect, digital photos depicting the defect, and copies of documentation evidencing product purchase date (such as a sales receipt or invoice). WARRANTY CLAIMS MUST BE SUBMITTED WITHIN THIRTY (30) DAYS FROM THE PRODUCT'S DEFECTIVE PERFORMANCE. CLAIMS SUBMITTED AFTER SUCH THIRTY (30) DAY PERIOD WILL NOT BE ELIGIBLE FOR WARRANTY SERVICE.

WARRANTY CLAIMS MUST BE SENT TO:

Westinghouse Residential Pumps
4400 Easton Commons
Suite 250
Columbus, OH 43219
Phone: (833) 594-0444
Email: support@respumps.westinghouse.com